

FinishLine II™

SUCTION FEED SPRAY GUNS



- **Economically-priced**
- **Available in HVLP or conventional models**
- **Durable, high quality construction**
High grade aluminum gun body
Aluminum retaining ring and adjusting knobs
Replaceable threaded baffle for economical servicing
Alloyed resin handle keeps gun weight to a minimum
Gun washer safe
- **Precision engineered to produce well-atomized, uniform spray patterns**
- **Accurate, repeatable settings**
Pointers on fluid and fan controls
- **Stainless steel fluid needle and alloy resin fluid tip**
- **One-quart aluminum "drip free" suction cup**
Two-position valve allows operation as a "drip free" cup or as a conventional suction cup
- **Includes**
One-quart aluminum suction feed cup (120011/TGC-545)
1.6 mm fluid tip (conventional gun)
2.2 mm and 1.8 mm fluid tips (HVLP gun)
Air adjusting valve with gauge (180006/HAV-501) (HVLP gun)

Specifications

HVLP Model

23 psi inlet pressure delivers
10 psi air cap pressure
at 11.4 cfm air volume

Note: Gun trigger must be pulled when adjusting air inlet pressure

519210 (FLG-463) Air Cap Test Kit

Provides consistent setup and regulatory proof of air cap pressure

Conventional Model

9.9 cfm at 40 psi inlet pressure

FinishLine II Suction Feed Spray Guns

Order No. Model No.	Type	Fluid Tip (mm)	Air Cap	Applications
611102 FLG-626-322	HVLP	2.2/1.8*	#3	General purpose, light to medium viscosity materials
611100 FLG-606-116	Conventional	1.6	#1	General purpose, light to medium viscosity materials

*HVLP models come standard with two sizes of fluid tips.

FinishLine™ Suction Feed Spray Guns

Suction Feed Spray Gun Models

611102 (FLG-626-322)
HVLP Suction Feed

611100 (FLG-606-116)
Conventional Suction Feed

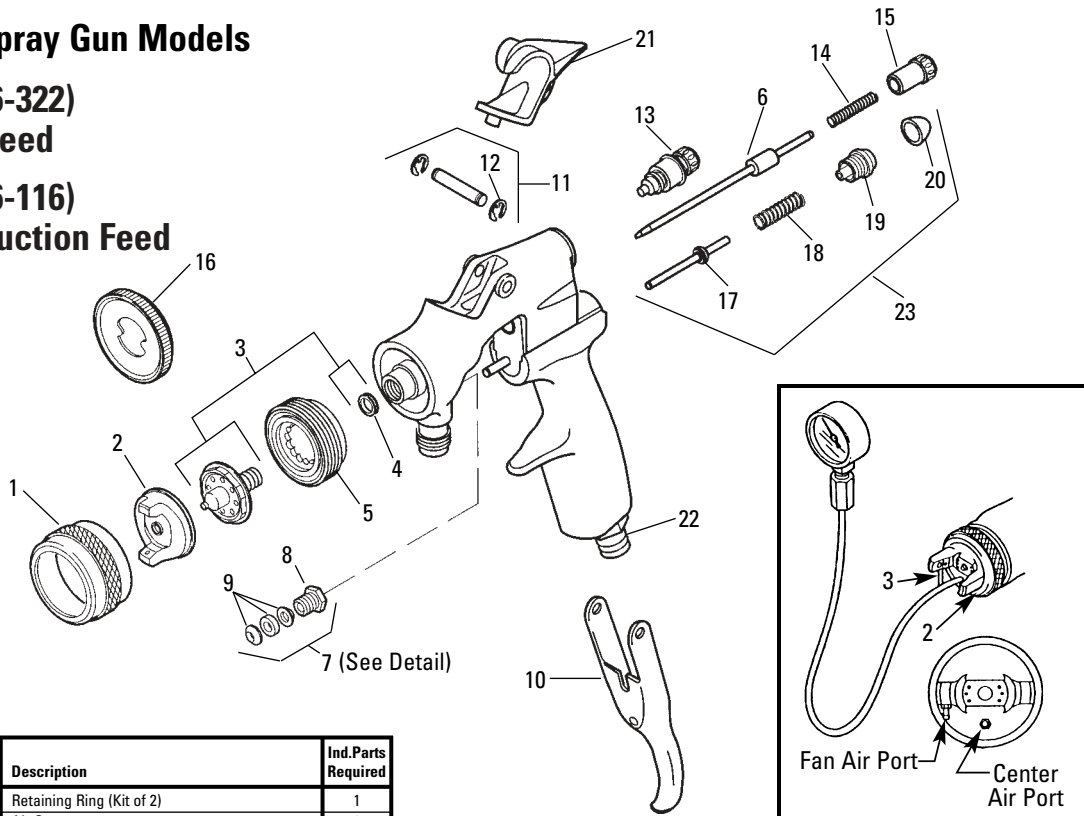

Ref. No.	Order No.	Model No.	Description	Ind. Parts Required
1	690002	FLG-101-K2	Retaining Ring (Kit of 2)	1
2	—	See Chart 1	Air Cap	1
3	—	See Chart 1	Fluid Tip, Seal and Tip Tool	1
+4	690015	FLG-4-1-K5	Fluid Tip Seal (Kit of 5)	1
5	690007	FLG-105	Baffle	1
6	690011	FLG-431	Fluid Needle	1
+7	690012	FLG-440-K5	Packing Kit (includes 1 packing nut and 5 packing sets)	1
+8	—	—	Packing Nut	1
9	192109	JGA-4035-K5	Packing Kit (Kit of 15)	1
10	519132	FLG-412	Trigger	1
+11	519029	FLG-8-K2	Trigger Stud Kit (Kit of 2)	1
+12	—	—	Circlip	2
13	690010	FLG-416	Spreader Adjustment Valve	1
+14	—	—	Spring	1
+15	690008	FLG-109-K2	Needle Adjusting Screw (Kit of 2)	1
+16	690009	FLG-111-K2	Fluid Tip Tool (Kit of 2)	1
+17	—	—	Air Valve Stem and Seal	1
+18	—	—	Air Valve Spring	1
+19	—	—	Air Valve Cap Body	1
+20	—	—	Air Valve Cap	1
21	—	—	Gun Hook	1
22	519054	FLG-40	Air Inlet Adapter	1
23	519134	FLG-414	Air Valve Service Kit	1
*24	—	—	Adapter, 1/2" NPS (M)	1
*25	—	—	Nut, 3/8" NPS (F)	1
*26	—	—	Cam	1
*27	190924	TGC-407-1-K3	Drip Free Valve & Gasket (Kit of 3)	1
*28	190391	TGC-9-K5	Tri Seal® Lid Gasket (Kit of 5)	1
29	190381	TGC-404	Lid Assembly (Quart)	1
30	190221	KR-428-2	Suction Cup Assembly (Quart)	1
31	120011	TGC-545	Suction Cup Assembly (includes #24-30)	1

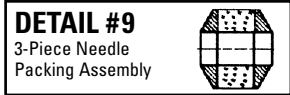

+NOTE: Repair Kit 690013 (FLG-480)
Contains:

Ref. No.	Description	Qty.
4	Fluid Tip Seal	1
7	Packing	1
8	Packing Nut	1
11	Trigger Stud	1
12	Circlip	2
14	Spring	1
15	Needle Adjusting Screw	1
16	Fluid Tip Tool	1
17	Air Valve Stem & Seal	1
18	Air Valve Spring	1
19	Air Valve Cap Body	1
20	Air Valve Cap	1

NOTE: See Section G-2 for TGC-545 Suction Cup parts breakdown.

Chart #1

Spray Gun Model Number	Spray Gun Order Number	No. on Air Cap	Ref. No. 2 Air Cap Part No.	Ref. No. 2 Air Cap Order No.	Ref. No. 3 Fluid Tip Part No.	Ref. No. 3 Fluid Tip Order No.	Fluid Tip Size
FLG-606-116	611100	1	FLG-1-1	690000	FLG-102-16K	690004	1.6 (Std.)
FLG-626-322	611102	3	FLG-1-3	690001	FLG-102-22K	690006	2.2 (Std.)
					FLG-102-18K	690005	1.8 (Std.)
					FLG-102-14K	690003	1.4 (Opt.)

Optional tips for FLG guns available as service parts only.

* A quantity of necessary parts is included in Repair Kit 690013 (FLG-480) for complete gun repair and should be kept on hand for service convenience.

* KK-5007 Repair Kit contains enough parts to repair one complete assembly.

Suffixes: -K5 designates kits of multiple parts. Example: JGA-4035-K5 is a kit of 5 packing sets.



ITW Automotive Refinishing
An Illinois Tool Works Company
1724 Indian Wood Circle, Suite J-K
Maumee, OH 43537-4048
Telephone 419-891-8100
Fax 419-891-8110
www.devilbiss.com

