



Horizontal Breathing Air - HBA

Breathe Easy with MAKO Breathing Air Systems from CompAir.

HORIZONTAL BREATHING AIR - HBA

Up to 414 bar g	9.9 - 56.4 m ³ /hr
Up to 6000 psi g	5.8 - 33.2 cfm
	165 - 940 l/min

The HBA open frame unit provides a lower cost breathing air system without sacrificing quality, flexibility or filling capacity.

OPEN FRAMED, LOW PROFILE PACKAGE

- Lightweight but rugged design
- Components fully contained within frame
- Belt and fan guard for added safety
- Choice of electric, petrol / gasoline and diesel drive options
- Optional wheels on smaller units for portability

EASY TO USE WITH GUARANTEED AIR QUALITY EXCEEDING EN 12021 / CGA GRADE D & E / NFPA 1500 AND MOST RECOGNISED STANDARDS

- Compressor interstage pressure gauges included as standard
- High quality filtration system designed and manufactured by CompAir
- Easy access to filter housing for quick cartridge replacement
- Full range of manual and automatic control options

MODULAR DESIGN FOR MAXIMUM FLEXIBILITY

- Easily incorporated into existing installations
- Single Outlet or Integrated Fill Panel with 2, 4 or 6 filling hoses (depending on model)
- Single or Dual Pressure filling capability
- Compatible with MAKO Containment Fill Station and Air Storage systems



For well over 50 years, CompAir and MAKO have been trusted breathing air system suppliers to Fire and Safety, Recreational and Professional Dive, Marine, Offshore and Defence industries across the globe.

Combining proven technology and global experience, the MAKO range brings you high quality breathing air you can trust.



The Heart of the MAKO design

CompAir has over 100 years of experience designing and manufacturing compressors.

The result is a 3 or 4 stage compressor block with:

- **Long operating life**
- **Extended service intervals and easy access for maintenance**
- **Low vibration and noise levels**
- **Proven technology for safe and reliable operation**
- **High quality manufacturing with ISO 9001 Quality Management System**

Breathe Easy with MAKO Filtration

Designed and manufactured by CompAir, the filtration exceeds international standards EN 12021 / CGA Grade D & E / NFPA 1500.

- **Filtration manufacturing process uses no adhesives ensuring there are no odours carried over**
- **Low cartridge cost per hour**
- **Easy access to filter housing allows quick cartridge replacement**

User Friendly Controls

The standard controller features illuminated On / Off push buttons, hours run meter, final stage pressure gauge, plus high air temperature, low oil level / pressure and high air pressure shutdown lights.

For those with more complex requirements, CompAir offers a number of control option upgrades giving maximum flexibility and peace of mind.

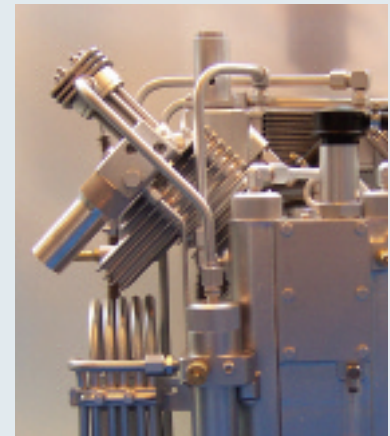

**BREATHE EASY WITH
PROVEN TECHNOLOGY
AT THE HEART OF
EVERY UNIT**

Monitoring made easy CMM MONITOR

Electronic CO and Purification monitoring:

- **Easy to read, simple to use**
- **Straight forward CO sensor / cell replacement**
- **Automatic calibration - the CO sensor automatically adjusts to ensure accurate measurement of CO by checking itself against two preset levels.**



Fully integrated controls for simple operation MEC CONTROLLER

All the advantages of the CMM Monitor, plus:

- **Full integrated system for user friendly control**
- **Self diagnosis with trouble shooting display**

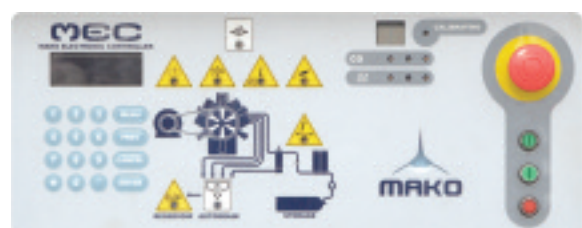

Flexible Filling Options

Whatever your filling requirements, CompAir has the solution for you.

A. Integrated Filling Panels

The HBA range can be fitted with an integrated filling panel for quick and easy charging up to 350 bar / 5000 psi

Filling Panel Options:

- 2, 4 or 6 filling hoses
- Single or dual pressure

Charging Connectors

The MAKO range provides a variety of connectors for cylinder filling, including:

200 bar / 2900 psi DIN • 300 bar / 4350 psi DIN • CGA 346 • CGA 347 • A Clamp / SCUBA Yoke

Filling Panels can be supplied as a remote unit on request.



B. Containment Fill Station

The Containment Fill Station range is a market leading solution providing the ultimate in safe and convenient filling.

Cylinders are placed in the unit via a simple pull down door on the front of the unit. Filling can only commence once the door is closed. In the event of a cylinder, hose or valve rupture the unit is able to contain the full impact of the rupture, protecting the operator from injury.

Options:

- 1, 2 or 3 positions for SCBA / SCUBA cylinders (size dependent)
- A variety of charging connections as shown in section A



C. Storage and Cascade Systems

Maximise the output of your breathing air system to cope with unpredictable or peak filling requirements.

Options:

- Horizontal or vertical storage racks are available in configurations of 2, 3, 4, 5 or 6 cylinders
- Cylinders can be supplied to meet DOT, ASME or CE specifications
- Cascade systems are available to optimise storage and filling capacity. These can be integrated into a Containment Fill Station or as a separate remote unit.



OPTIMISE YOUR BREATHING AIR SYSTEM TO FIT YOUR CURRENT AND FUTURE REQUIREMENTS
ALL COMPONENTS CAN BE EASILY INCORPORATED INTO EXISTING INSTALLATIONS

TECHNICAL DATA

MODEL	MAX PRESSURE		STAGES	CHARGING RATE (0 - MAX PRESSURE)			COMPRESSOR rpm	MAX INTEGRATED FILL HOSES
	bar	PSI		m ³ /hr	l/min	cfm		
HBA04	350	5000	3	9.9	165	5.8	1300	2
HBA05	350	5000	3	14.6	243	8.6	1300	2
HBA06	350	5000	4	22.3	372	13.1	1340	4
HBA07	350	5000	4	31.8	530	18.7	1800	4
HBA08	350	5000	4	43	717	25.3	1530	6
HBA09	350	5000	4	52	867	30.6	1800	6
HBA06H	414	6000	4	23.8	397	14	1340	4
HBA07H	414	6000	4	35.2	587	20.7	1800	4
HBA08H	414	6000	4	45.9	765	27	1530	6
HBA09H	414	6000	4	56.4	940	33.2	1800	6

MODEL	ELECTRIC				DIESEL				PETROL/GASOLINE			
	POWER		WEIGHT		POWER		WEIGHT		POWER		WEIGHT	
	kW	hp	kg	lbs	kW(b)	hp	kg	lbs	kW(b)	hp	kg	lbs
HBA04	4	5	200	435	6	8	320	710	6	8	310	680
HBA05	5.5	7.5	210	460	7.5	10	330	725	8.2	11	330	725
Dimensions	1228mm x 470mm x 800mm / 48" x 18.5" x 31.5"				1473mm x 738mm x 1130mm / 58" x 29" x 44.5"				1473mm x 738mm x 1130mm / 58" x 29" x 44.5"			
HBA06(H)*	7.5	10	315	690	13.4	18	560	1240	12	16	320	710
HBA07(H)*	11	15	335	735	20	27	625	1380	15	20	335	740
Dimensions	1473mm x 738mm x 1130mm / 58" x 29" x 44.5"				1575mm x 1054mm x 1181mm / 62" x 41.5" x 46.5"				1473mm x 738mm x 1130mm / 58" x 29" x 44.5"			
HBA08(H)*	15	20	380	835	20	27	655	1440				
HBA09(H)*	18.5	25	400	880	27	35.9	685	1510				
Dimensions	1473mm x 738mm x 1130mm / 58" x 29" x 44.5"				1575mm x 1054mm x 1181mm / 62" x 41.5" x 46.5"							

NOTES:

1. All technical details are subject to change.
2. Performance figures are typical and are not the full range available.
3. Figures based on inlet conditions of 20°C / 68°F, 1.013 Bar / 14.7 PSI.
4. Charging Rates measured in accordance with CompAir Ipswich standard N° 27 Type 'A'.
5. Electric motors are available in 50 & 60 Hz, Single & 3 Phase versions and with multiple voltage options.
6. Tested and certified to equivalent of UL 1450 Standards. Conforms to all applicable CE directives.
7. For optimum efficiency, siting of the units must not impair the integral air blast cooling.

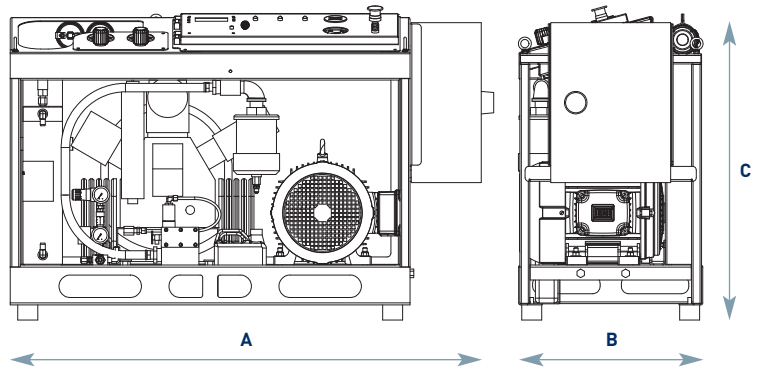

* For models indicated, control box is mounted within the frame.



www.compair.com
email@compairmako.com

The CompAir standard is one of continuous improvement and we therefore reserve the right to alter specifications and processes without prior notice. All products are sold subject to the Company's conditions of sale.

re-order ref: 069E, 08/2007



Ref No. 926290